

Nest Table



Nest Table

The Nest Table is a modern high quality table for all kinds of modern spaces. The thin tubular steel frame provides a light expression and ensures a very strong and durable base of functionality. The 20mm table top in Fenix Nanotech Laminate or Oak Veneer completes the elegant Nordic look and makes the High Nest Table suitable for a large range of different environments. In terms of additional functional features, the Fenix Nanotech laminate offers: anti fingerprint, scratch resistancy, and low light reflectivity. Available in two different heights, and part of the Nest family that comprises additional tables, chairs, and sofas.

Designed by Form Us With Love

Form Us With Love was founded in 2005 and since its conception, the studio has burned with a passion for design and its democratic potential. Its belief is that we all have a right to meaningful design. At the studio's core lies a process that blends traditional creative practices with a lean, strategic application. The central intention is to evolve with the needs of each project, its place in the market, and the ever-changing needs of real people.



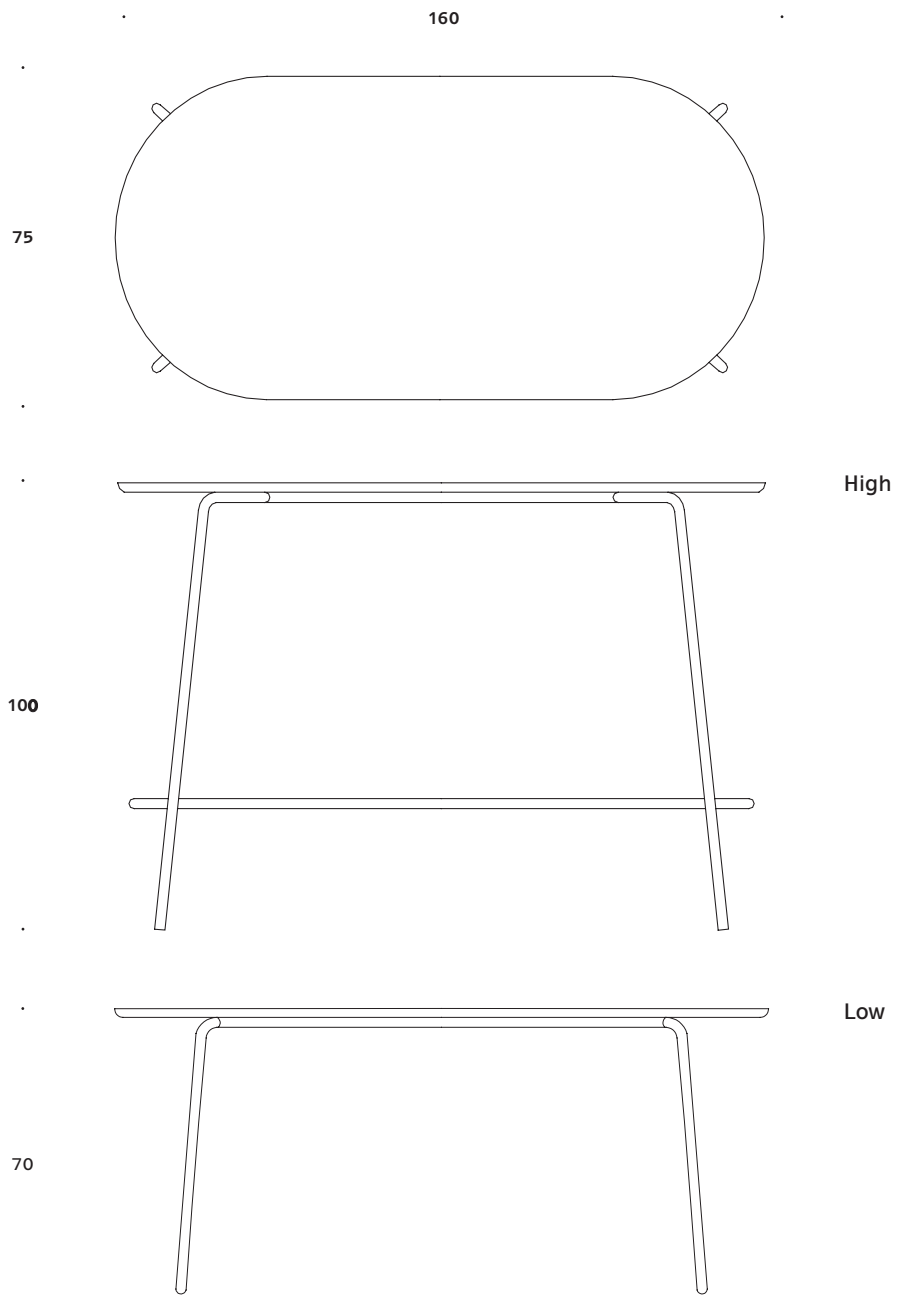

Dimensions defined in centimeters

Design

Form Us With Love

Materials

Table top in black Fenix NANOTECH lamintate RAL 0720 / Oak veneer.
Frame in in black RAL 9005 / light gray RAL 7035 powder coated steel



info@in-mezzo.com
www.in-mezzo.com